

I2C-IN830M, I2C-IN830MA

8-Input Optocouplers I2C-bus, DIN rail supports

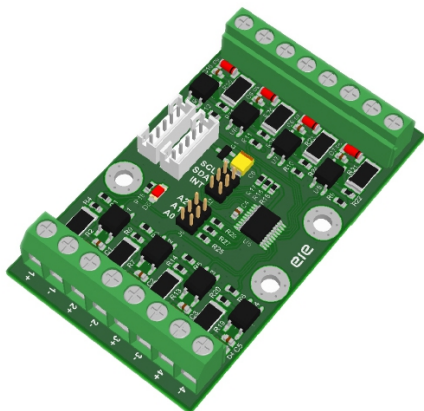

Features

- PCF8574 and PCF8574A I2C chips
- Support 100kHz I2C bus frequency
- On-board I2C bus pull-up resistors
- Address by 3 jumpers for use of up to 8 addresses
- Up to 16 boards on a bus
- Interrupt output signal
- On-board interrupt pull-up resistor
- Compatible with most microcontrollers
- 8 Optically isolated digital input channels
- 15-30VDC input voltage, I2C-IN830M0, I2C-IN830MA0
- 5-30VDC input voltage, I2C-IN830M1, I2C-IN830MA1
- 3700VDC isolation input voltage
- Operating power supply voltage 3.3-5.5VDC
- Inverse polarity protection circuits
- DIN-rail supports
- PCB size 42.50x72.00mm

Description

These are 8-channel opto-isolator boards for input expander over I2C bus. Each input of the I2C-IN830M0 and I2C-IN830MA0 accepts 15-30VDC. It is suitable for mechanical contact switching devices such as relay switches, push-buttons and switches. But each input of the I2C-IN830M1 and I2C-IN830MA1 accepts 5-30VDC. It is suitable for solid-state switching devices such as proximity switches. The boards use PCF8574 and PCF8574A for I2C chips. They support 100KHz bus speed and 3.3-5.5VDC bus voltage. Each board has three jumpers for setting an own I2C bus address. So they can be connected up to 16 boards on a bus by setting different addresses. Also there are I2C bus pull-up resistors and interrupt pull-up resistor on board which they can be enabled by jumpers.

The board can be placed on DIN rail PCB holder which can be plugged on a DIN rail tray.

Diagrams

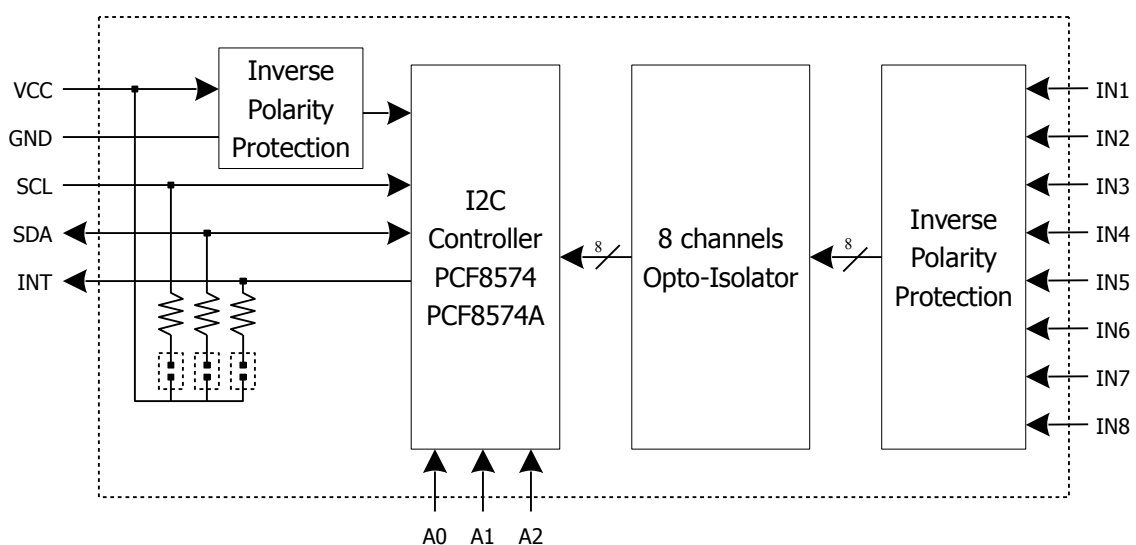

Figure 1: Block Diagram

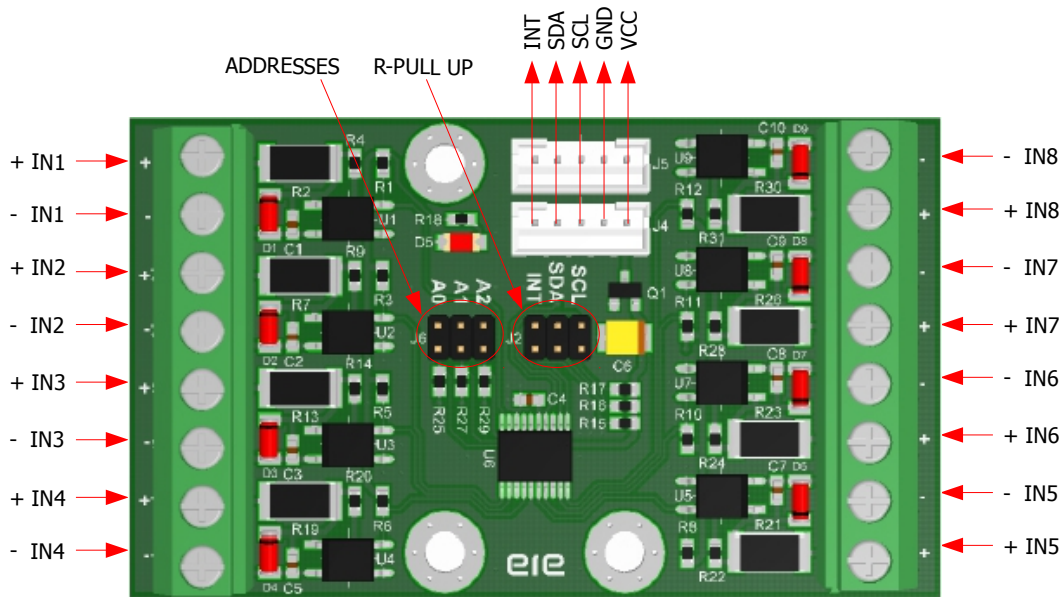

Figure 2: Board Diagram

Table 1: Pin Descriptions

Symbol	Descriptions
VCC	Power supply input voltage 3.3-5.5VDC
GND	Ground
SCL	I2C bus serial clock signal
SDA	I2C bus serial data signal
INT	Interrupt output signal
R-PULL SDA	A jumper for selecting 10K pull-up resistor of SDA signal
R-PULL SCL	A jumper for selecting 10K pull-up resistor of SCL signal
R-PULL INT	A jumper for selecting 10K pull-up resistor of INT signal
A0	A jumper for selecting address A0
A1	A jumper for selecting address A1
A2	A jumper for selecting address A2
+IN1 ... +IN8	Positive voltage for input1 to input8
-IN1 ... -IN8	Negative voltage for input1 to input8

I2C Bus Pull-Up Registers

The I2C bus wants pull-up resistors for SCL and SDA lines. The board has two of 10k pull-up resistors for this purpose. These resistors can be enabled by closing jumpers. These resistors have to be enabled if there is no any pull-up resistor on a bus or a microcontroller board.

When multiple boards are connecting together on a bus. Usually the pull-up resistors of only one board are enabled. The bus is very strong if all pull-up resistors are enabled. So the microcontroller cannot drive the bus.

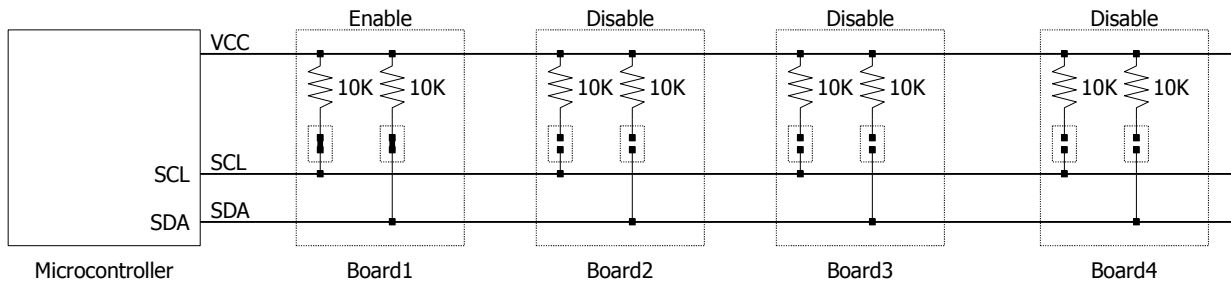

Figure 3: I2C bus pull-up resistors

Interrupt Signal

Interrupt output signal (INT) on board can be connected to the interrupt input pin of microcontroller. The board sends an interrupt signal on this line. So the board can inform the microcontroller if there is incoming voltage on its inputs without having to poll over the I2C bus. The interrupt output pin is an open-drain and it is connected to 10K pull-up resistor via a jumper.

When boards are connected together on an interrupt line. Usually the only one pull-up resistor has to be enabled. Each board takes logical OR to another boards, many interrupt signals can occur at the same time.

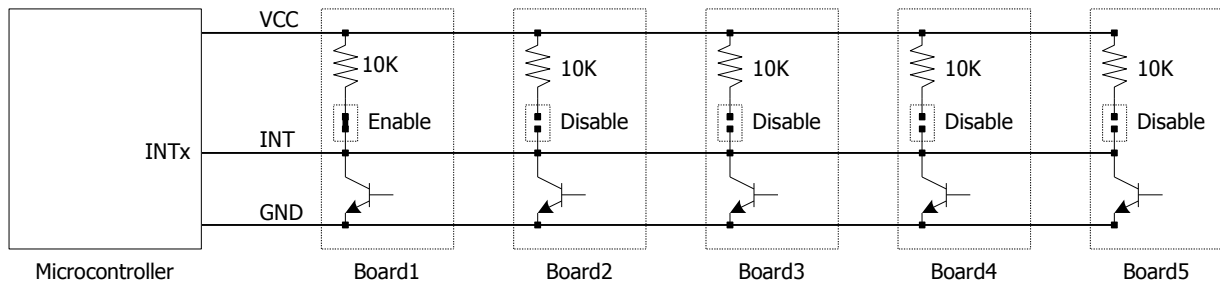

Figure 4: Logical OR interrupt signals

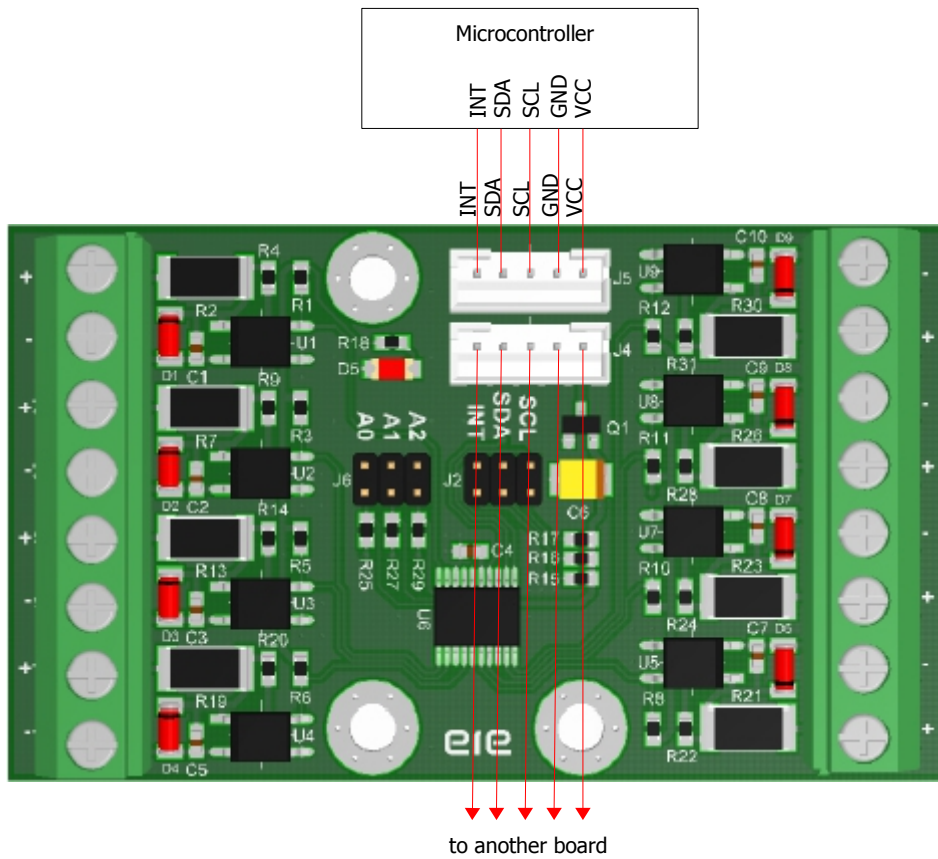

Figure 5: Interfacing

The boards can be connected all together up to 16 boards on a bus by connecting 8 boards of I2C-IN830M and 8 boards of I2C-IN830MA. Because each board has own address which is difference to address of another boards.

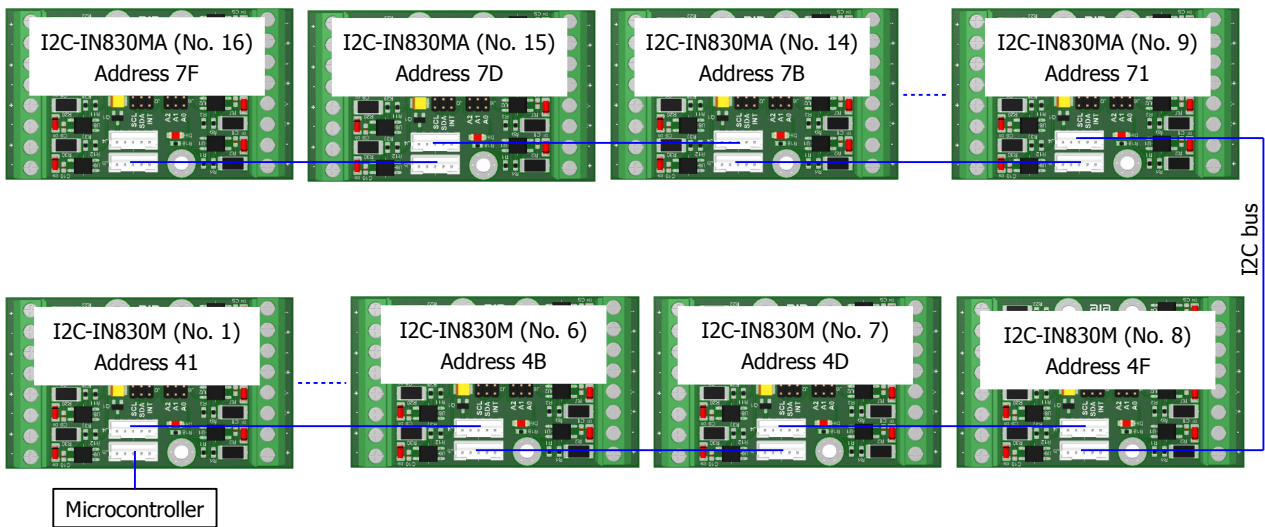

Figure 6: Boards on a bus

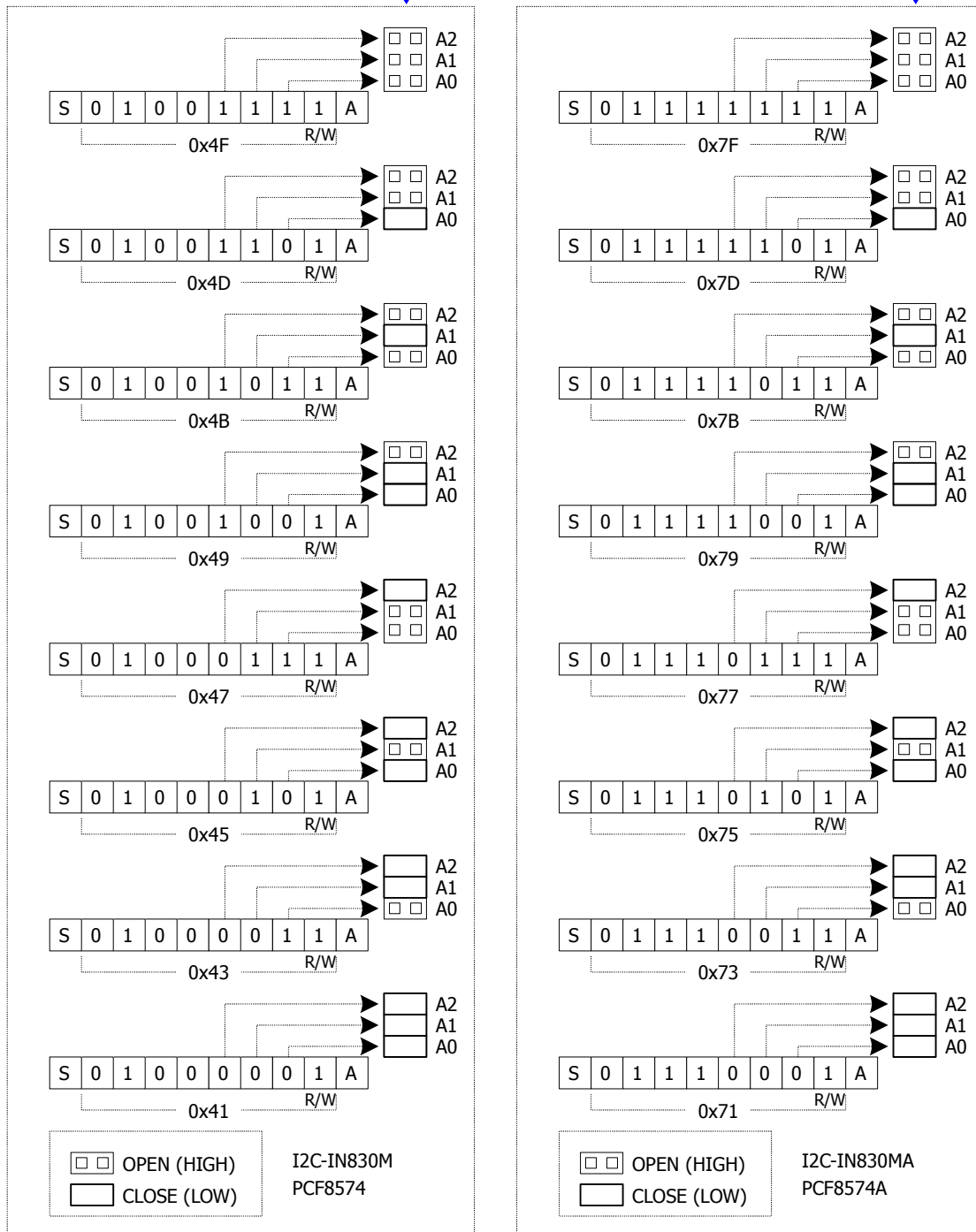
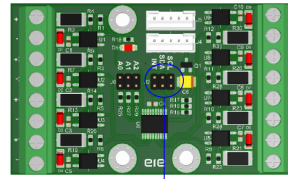

Figure 7: Addressing

Each board can be defined own address by setting jumper A0, A1 and A2 as above figure.

Input Diagram

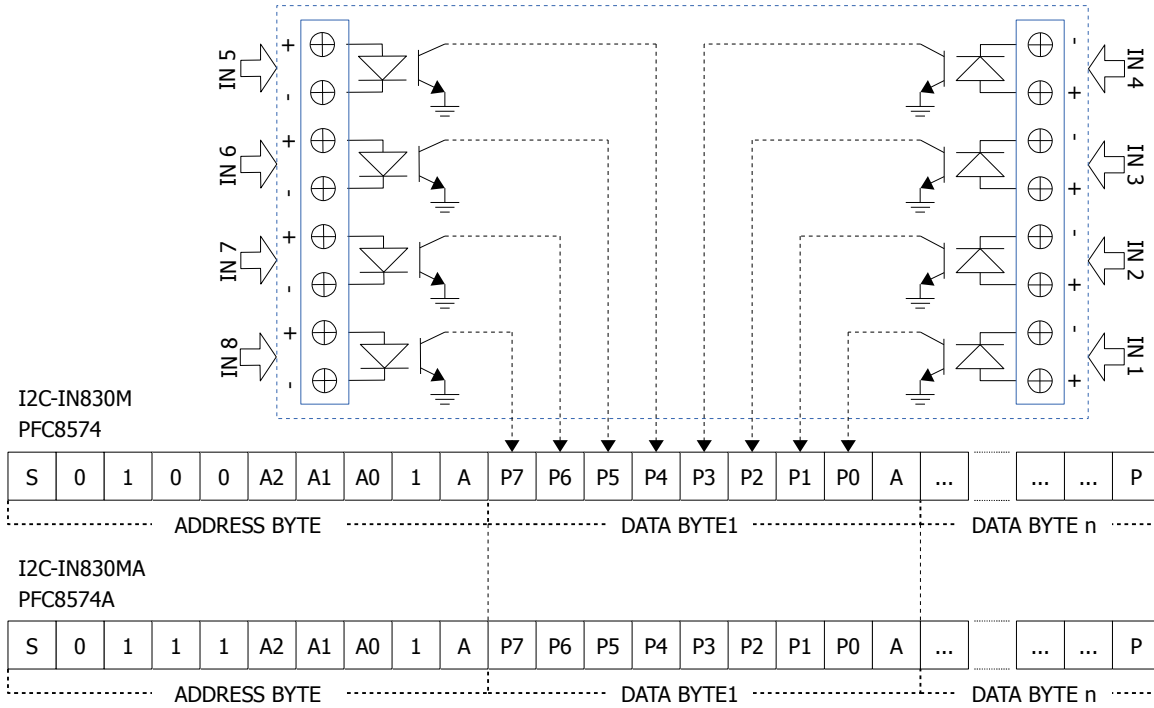

Figure 8: Input Data Frame

When inputs are read through I2C protocol. The first byte is address and the second byte is data of inputs. IN1 will pass to P0 and IN2 will pass to P1 respectively, until IN8 will pass to P7.

Table 2: Absolute maximum ratings at VCC = 5VDC

PAPAMETERS	I2C-IN830M0, I2C-IN830MA0	I2C-IN830M1, I2C-IN830MA1
Bus frequency	100Khz max	100Khz max
I2C chips	PCF8574 is used in I2C-IN830M0 PCF8574A is used in I2C-IN830MA0	PCF8574 is used in I2C-IN830M1 PCF8574A is used in I2C-IN830MA1
Bus logic voltage	3.3-5.5 VDC	3.3-5.5VDC
Max input voltage	30.0 VDC	30.0 VDC
ON voltage/current	15.0 VDC min., 4mA 24.0 VDC, 7mA 30.0 VDC, 8.7mA	5.0 VDC min, 3.5mA 12.0 VDC, 10.8mA 24.0 VDC, 22.8mA 30.0 VDC, 29mA
OFF voltage/current	5.0 VDC max., 1mA	2.0 VDC max , 1mA
Input impedance	3.3Kohm	1Kohm
Max. boards on a bus	16 boards	16 boards
Optical isolated input voltage	3.7kVDC	3.7kVDC
Input channels	8 channels	8 channels
Operating Temperature	0-70 C	0-70 C

Dimensions

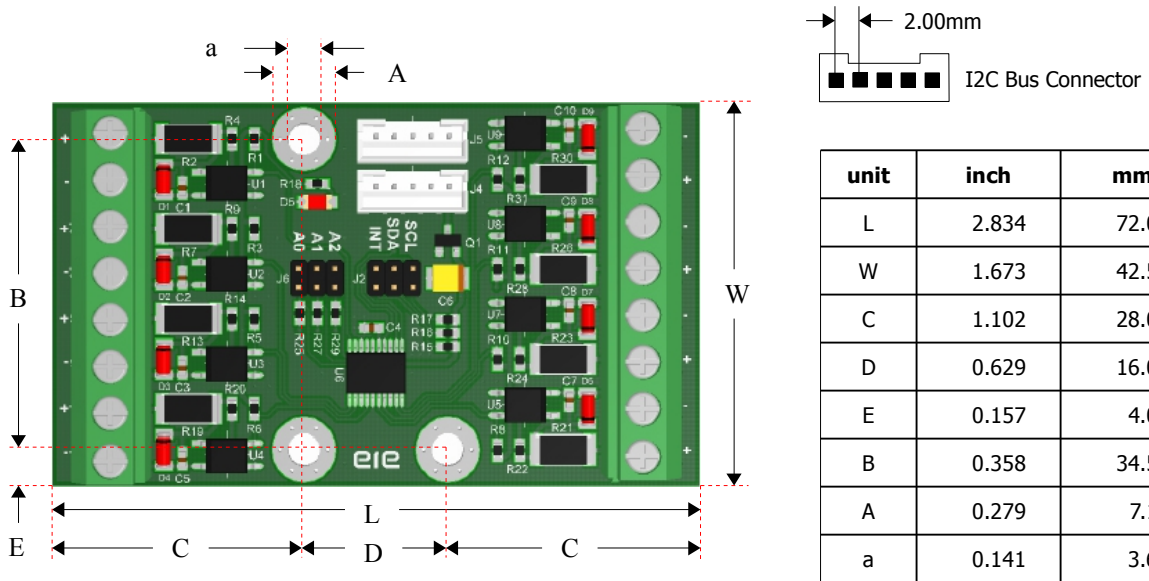

Figure 9: Dimensions