

EI2C-9AG, EI2C-9AGA

I2C Bus 8-Input Photocouplers

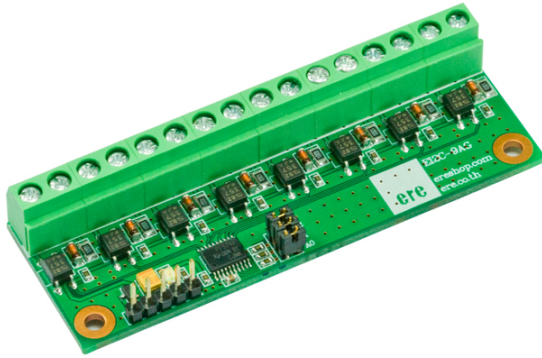

Features

- PCF8574 and PCF8574A I2C bus controller
- 8 Photocouplers
- Power supply input voltage 2.5V-5.5V
- 100kHz I2C bus frequency
- Address by 3 jumpers for use of up to 8 addresses
- Up to 16 boards on one bus
- Interrupt output pin
- Compatible with almost microcontrollers
- 6V to 15V continuous input voltage
- More than 15V can be, need external resistor
- Inverse polarity protection circuits
- Small board, PCB size 28x81.5mm

Descriptions

These are boards for remote 8-input expander for I2C bus based on PCF8574 and PCF8574A. Making it ideal as an isolation input expander for I2C bus. They are designed to compatible with almost 2.5V to 5.5V microcontrollers.

The PCF8574 and the PCF8574A are the I2C bus controllers which talk to microcontroller and then read status of input voltages from photocouplers. The PCF8574 and the PCF8574A support 100kHz bus frequency. And they can be connected to 2.5V–5.5V external logic voltage of I2C port of microcontroller.

The board has interrupt signal. On this line, the remote I/O can inform the microcontroller if there is incoming data on its inputs.

The boards have 8 photocouplers for input voltages. Each inputs support 6V–15V continuous input voltage and up to 30V for pulse input voltage. More than 15V of continuous voltage can be applied but need external resistor.

The boards are addressed by 3 jumpers to make 8 different addresses. So that 8 boards can be connected together on one bus. Moreover 16 boards can be connected together on one bus when they have 16 different addresses. By this way, 8 boards of the PCF8574 and 8 boards of the PCF8574A can be connected together on one bus. Because the PCF8574 doesn't have same address as the PCF8574A.

The boards have inverse polarity protection circuit for power supply input voltage to prevent damage from a mistake of connection. The boards have LED to show status of the power supply input voltage.

The boards have a small PCB size 28x81.5mm.

Board Diagram

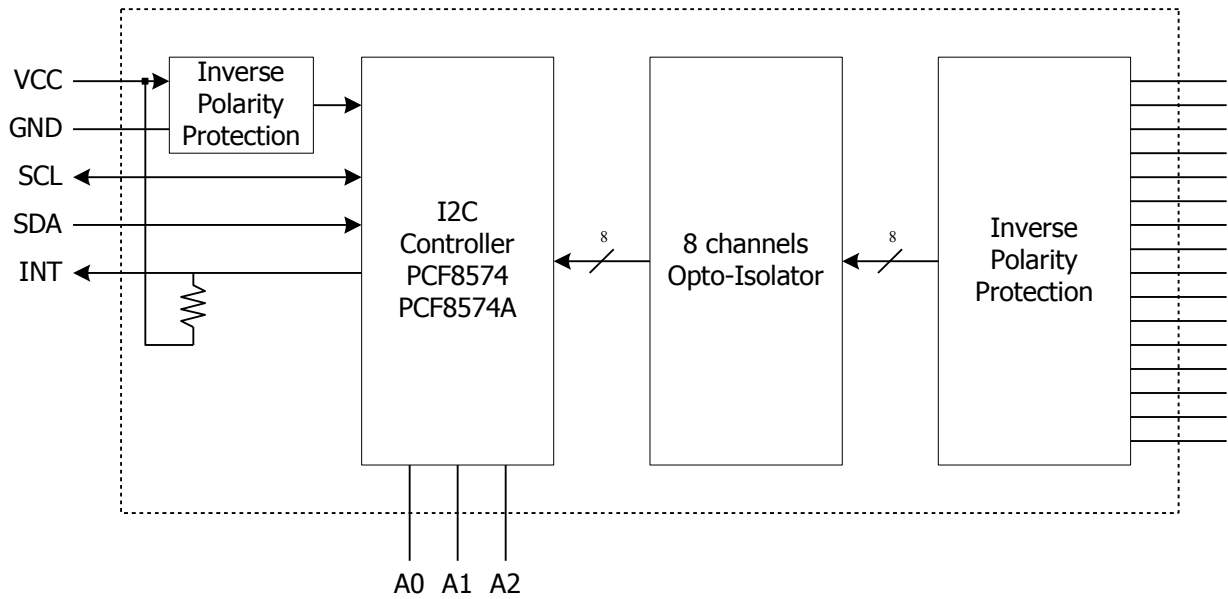

Figure 1: Board Diagram

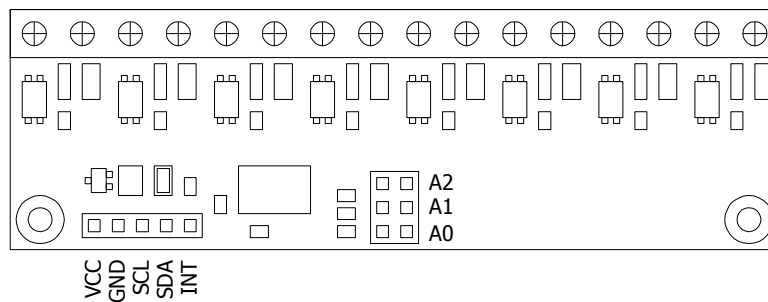

Figure 2: I2C bus and input voltage pins

Bus Signals

5-pin IDC(2.54mm) connector consists of VCC, GND, SCL, SDA and INT signals. The VCC and GND are power supply which must be supplied from external. The board has an inverse polarity protection circuit to prevent damage from inverse polarity of VCC and GND. The SCL and the SDA are I2C bus signals which must be connected to SCL and SDA pins of microcontroller. For the last signal is INT which can be connected to the interrupt pin of the microcontroller.

Interface To Microcontroller

VCC and GND must be supplied from external and also on board has an LED to show power supply voltage status. The SCL and SDA pins must be connected to SCL and SDA pins of microcontroller respectively. Remember 10K resistors must be connected to pull-up the SCL and the SDA signals of I2C bus, if no these resistors on the microcontroller board. The INT signal may be connected to the interrupt pin of microcontroller to informs the microcontroller if there is incoming data on its inputs.

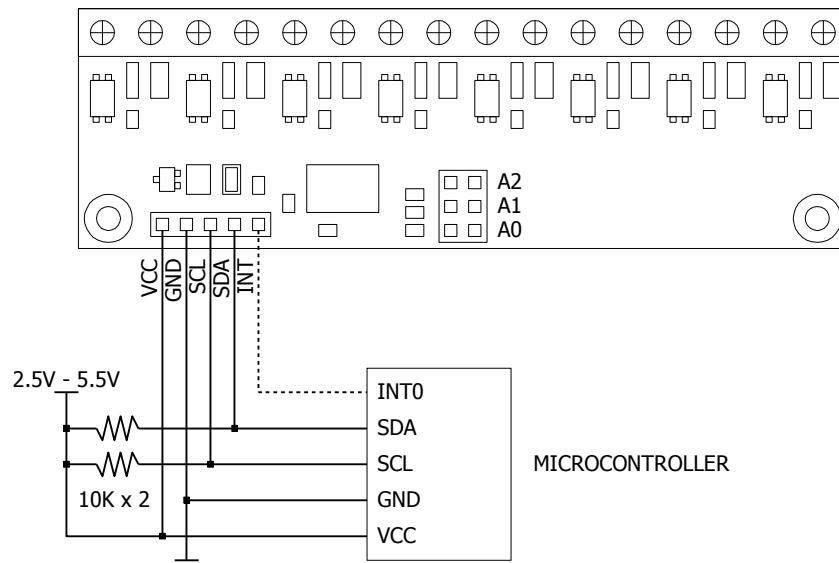

Figure 3: Connect To Microcontroller

Bus Address

The board use PCF8574 and PCF8574A as remote input expander for I2C bus. Which the PCF8574 and the PCF8574A have address as figure below. Bits D3,D2,D1 of data frame are changed by jumpers of A2, A1 and A0 respectively.

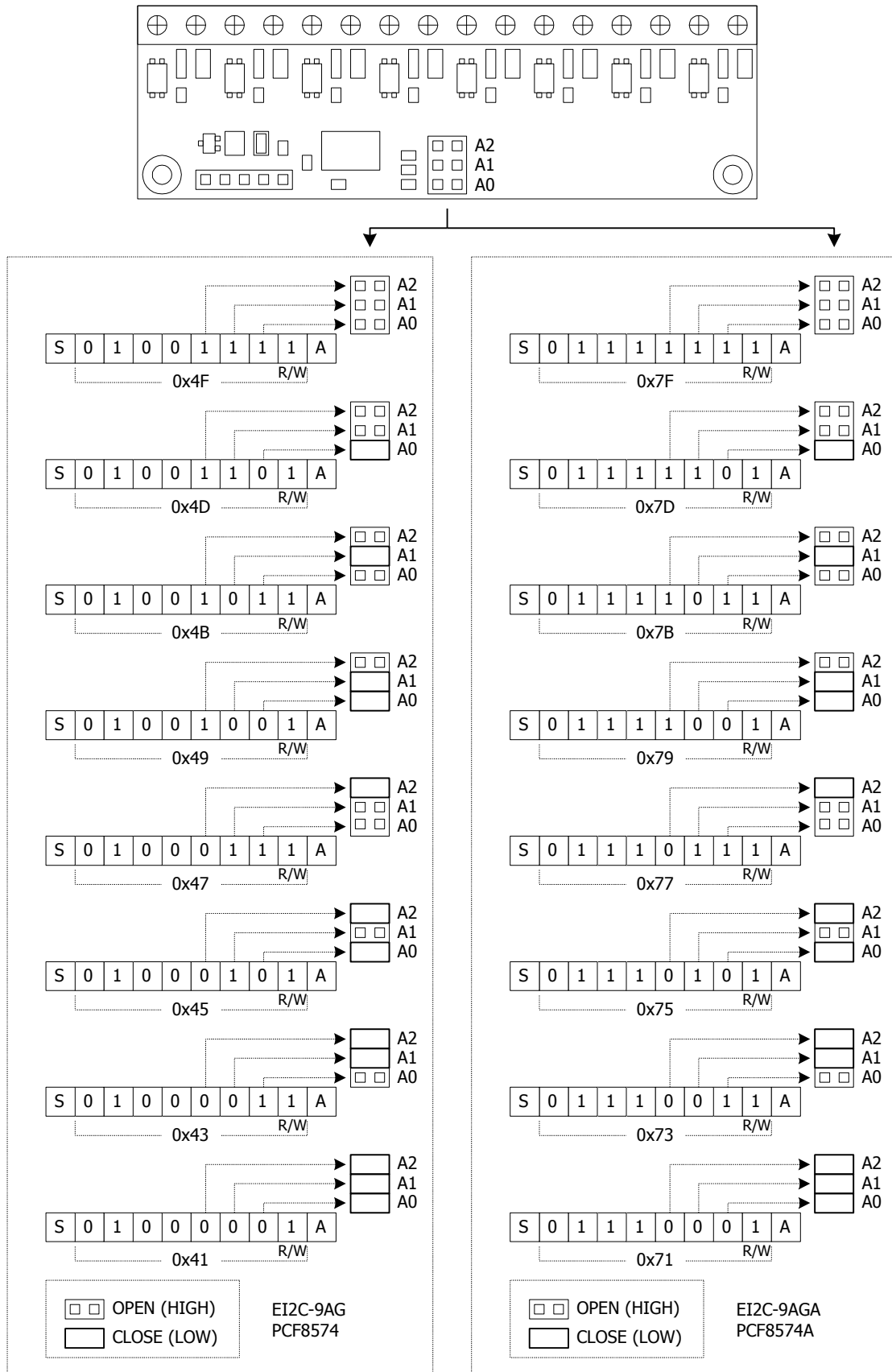

Figure 4: Addressing

Input Diagram

The board use photocouplers to isolate input signals from the PCF8574 and the PCF8574A. Each inputs can support up to 15V when input voltage is continuous voltage. However they can support up to 30V when pulse voltage is supplied. All inputs have the inverse polarity protection circuits to prevent damage of photocouplers from inverse polarity of input voltage.

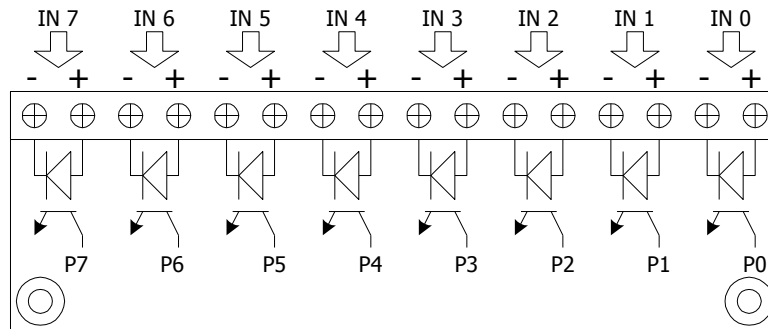

Figure 5: Input Diagram

If more than 15V of continuous voltage is applied into inputs of board. External resistor is needed for this condition. The board inputs are limited 15mA for input currents. So the external resistors has to limit the input currents. The input currents aren't more than 15mA.

Example. If 24V of continuous input voltages are applied to the inputs of board and 2.5K resistors are used, the current is $24V/2.5K = 9.6mA$. So the 2.5K resistors can be used because the current is less than 15mA. Next, to calculate the power of the resistors from $(I \times I \times R)$. The power is $(9.6mA \times 9.6mA \times 2.5K) 0.23mW$. Also the 0.25W can be used.

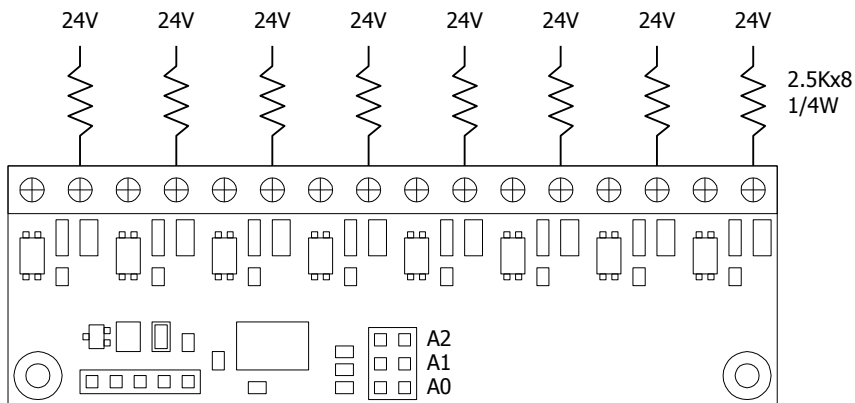

Figure 6: Extra Input Voltage

When read inputs of board via the PCF8574 and the PCF8574A. The logic of these inputs will be placed on data frame of the PCF8574 and the PCF8574A as figure.

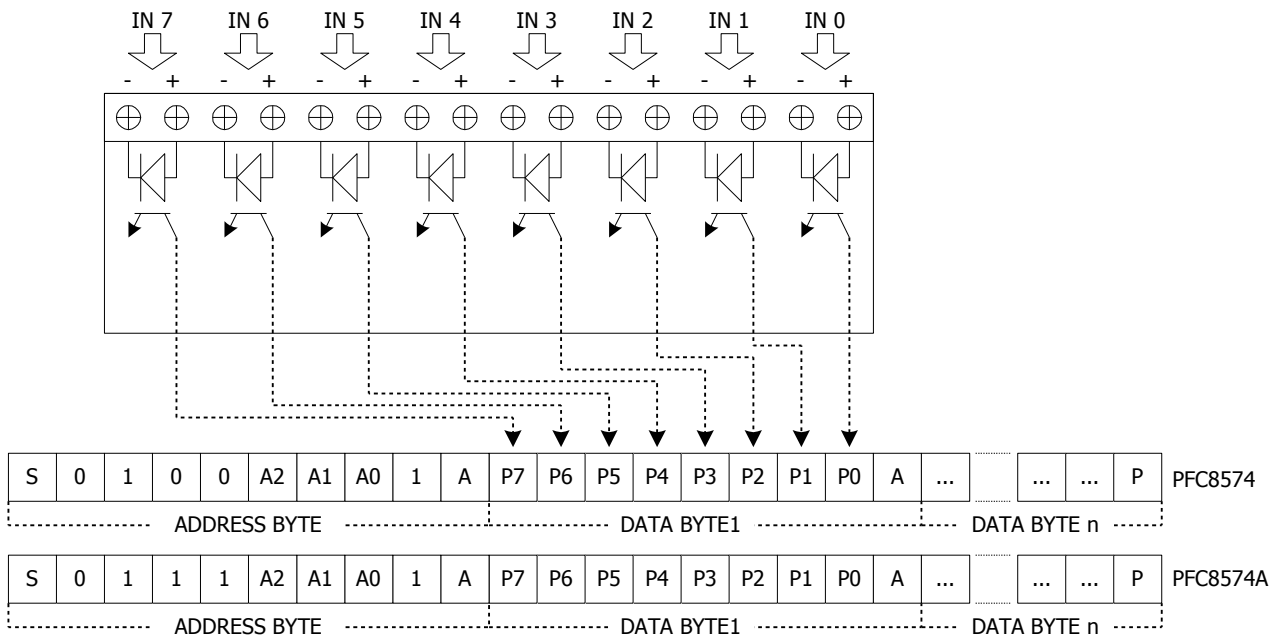

Figure 7: Input Data Frame

Application Note 1

Connect constant voltages to inputs of board directly.

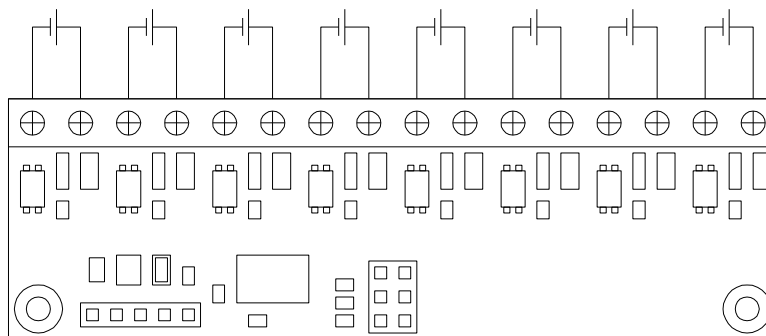

Figure 8: Constant Input Voltages

Application Note 2

Use switches to on/off input voltages.

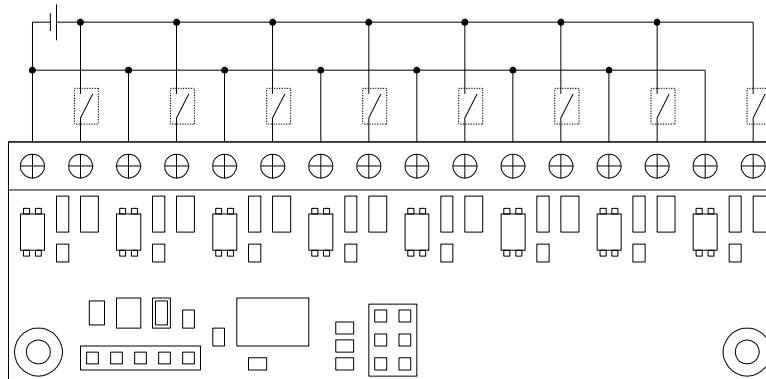

Figure 9: Switch Input Voltages

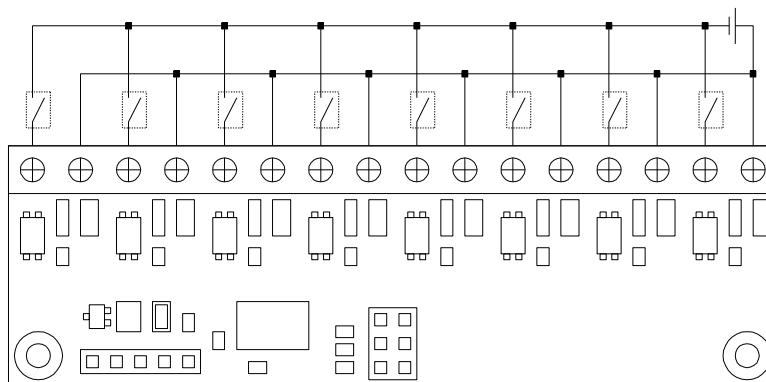

Figure 10: Switch Input Grounds

Application Note 3

Use transistors to on/off input voltage.

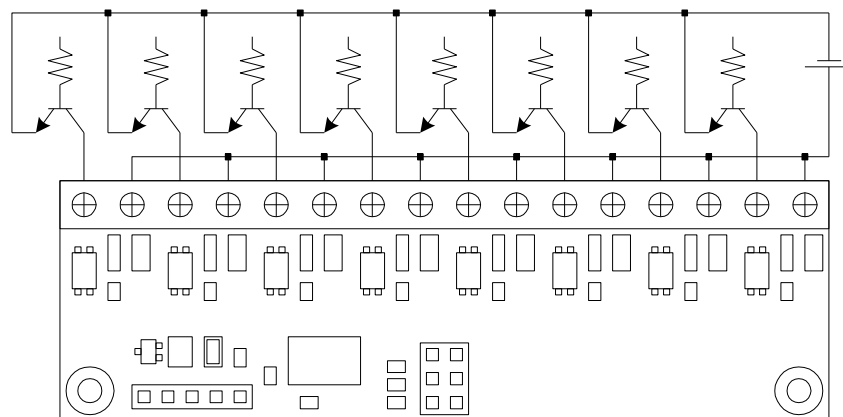

Figure 11: NPN Transistors, Common Emitter

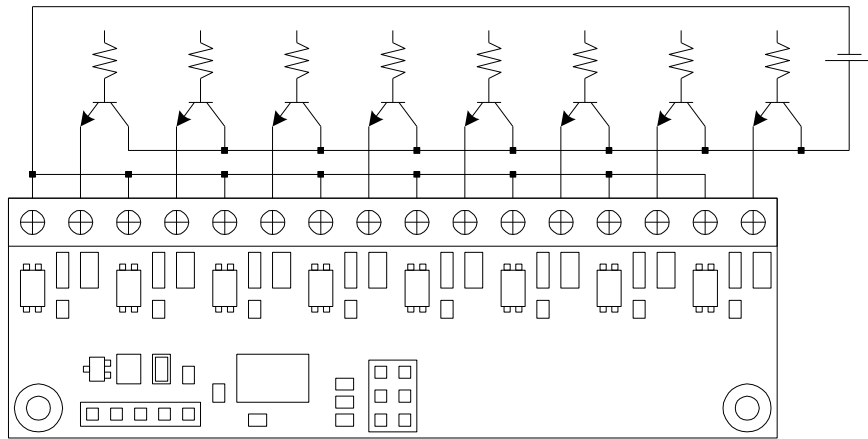

Figure 12: NPN Transistors, Common Collector

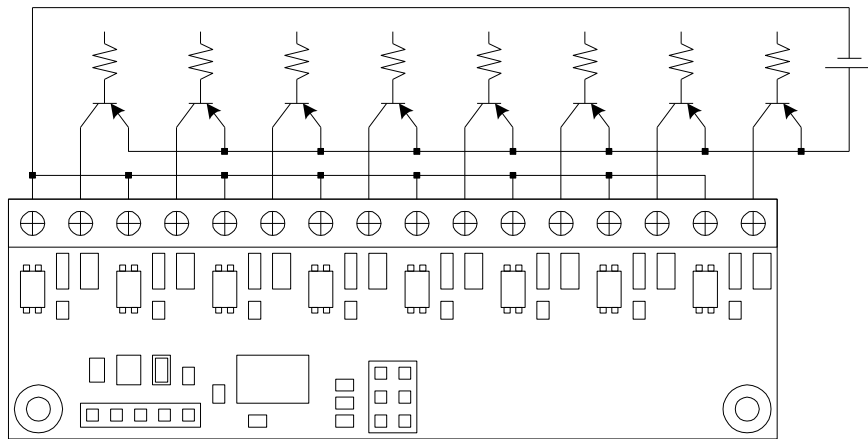

Figure 13: PNP Transistors, Common Emitter

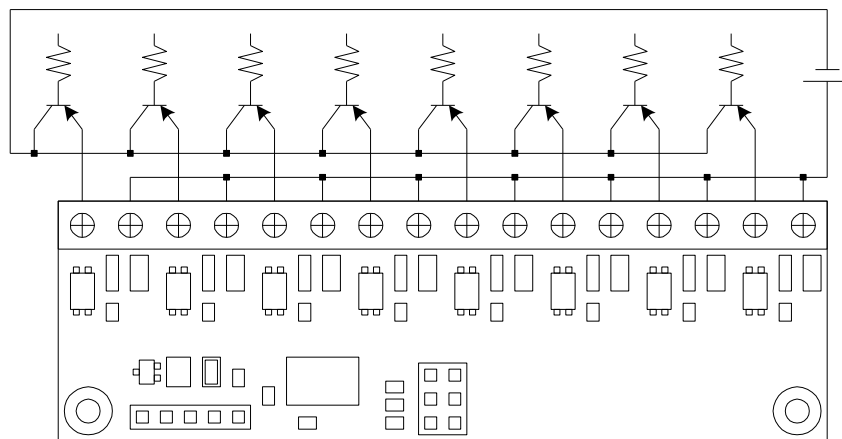

Figure 14: PNP Transistors, Common Collector

Application Note 4

Use several input types to turn on/off input voltages

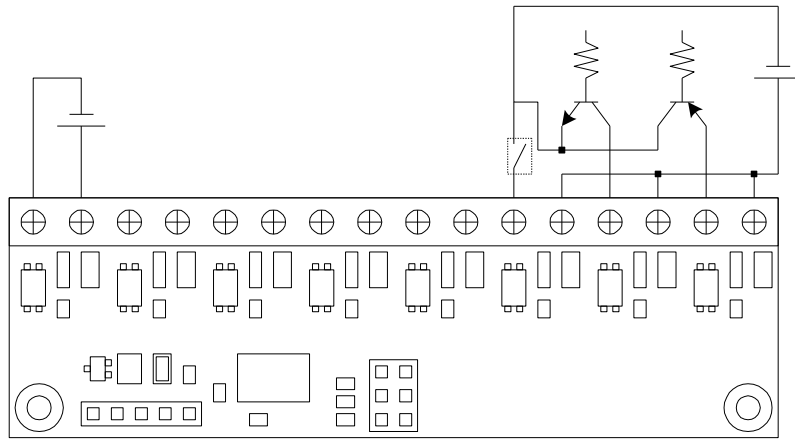

Figure 15: Switch Input Voltages

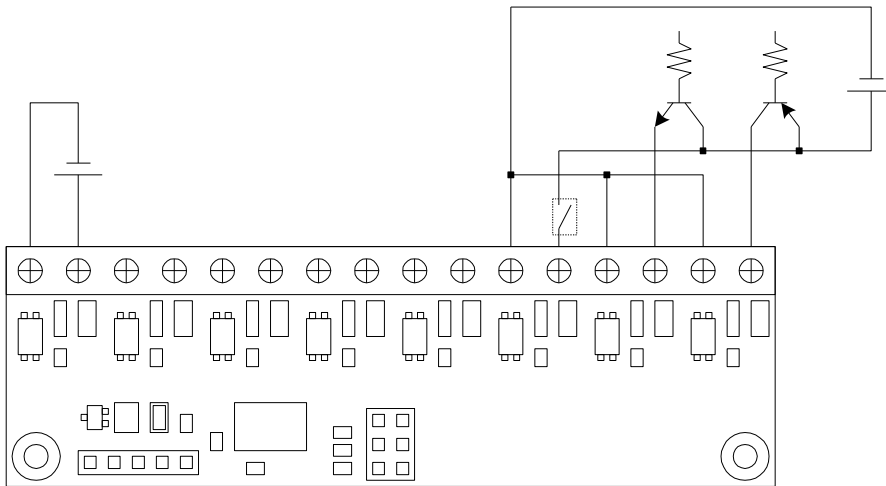

Figure 16: Switch Input Voltages

Specifications

Table 1: Absolute Maximum Ratings

Bus frequency	100Khz	
Maximum board on a bus	8(16) boards	
Maximum input voltage	6 to 15V (continuous voltage), 6 to 30V (pulse voltage)	
Input isolation voltage	3.7k Vdc	
Input channels	8	
Input currents	~4mA	input voltage = 6V
	~10.8mA	input voltage = 12V
	~13.8mA	input voltage = 15V
Power supply input voltage	2.5V – 5.5V	

Table 2: Board Comparisons

	EI2C-9AG	EI2C-9AGA
Max. Bus frequency	100kHz	100kHz
Power supply input voltage	2.5V – 5.5V	2.5V – 5.5V
Logic voltage	2.5V - 5.5V	2.5V – 5.5V
Input voltage	6V - 15V	6V - 15V
Chips	PCF8574	PCF8574A

Dimensions

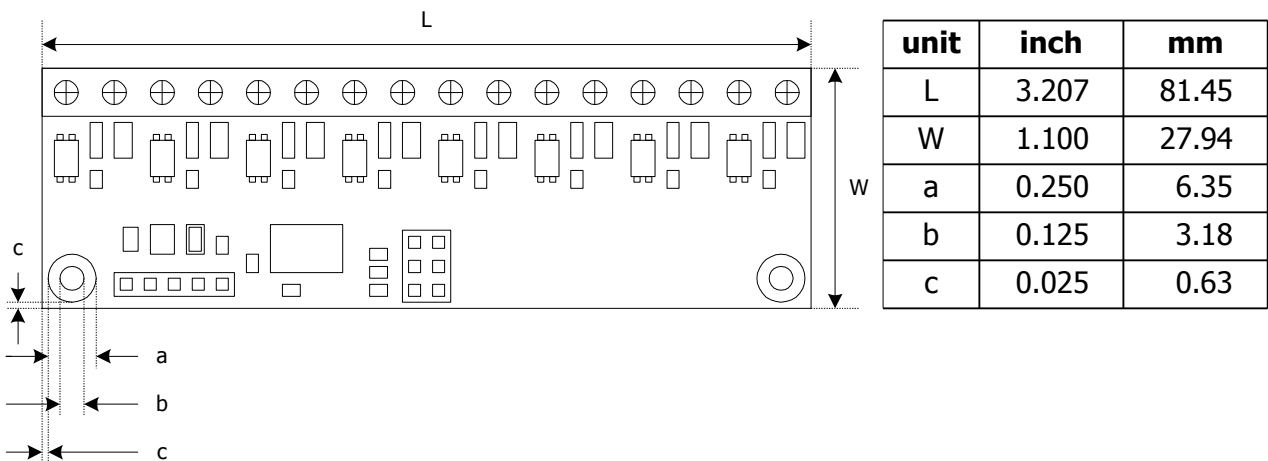

Figure 17: Board Dimensions